

Model 531 4-20 Milliamp Loop Calibrator Operating Instructions

Basic Keypad Operations

J EZ-Check™ Switch

SOURCE mode: Slide the switch to select from Hi and low range pre-set values and the mid ranger (Dial) is selectable. Dial the mid range value and it will store the value with-in 5 seconds automatically.

READ mode: Slide the switch to recall minimum and maximum readings. Press the **EZ-Dial™ Knob** to clear the stored values.

K SOURCE/OFF/READ Switch

Slide the **SOURCE/OFF/READ Switch** to **SOURCE** to output a mA signal and to do 2 - wire transmitter simulation. Use the **READ** position to read mA signal and power & measure 2 – wire transmitter.

f EZ-Dial™ Knob

Turn the knob to change display in 0.01mA increments. Push and turn for faster dialing. Push without turning to clear EZ-Check™ HI/LO points in READ mode.

Press twice to select options:

In **Source** mode select –
% or mA
2-Wire Transmitter Simulate
% or mA
low power (15V) or High power (24V)

In **Read** mode select -
% or mA
Power and Measure 2-Wire Transmitter
% or mA
low power (15V) or High power (24V)

HART® Protocol

An internal jumper enables the Power & Measure 2 – wire transmitter mode to be compatible with HART® communicators and transmitters.

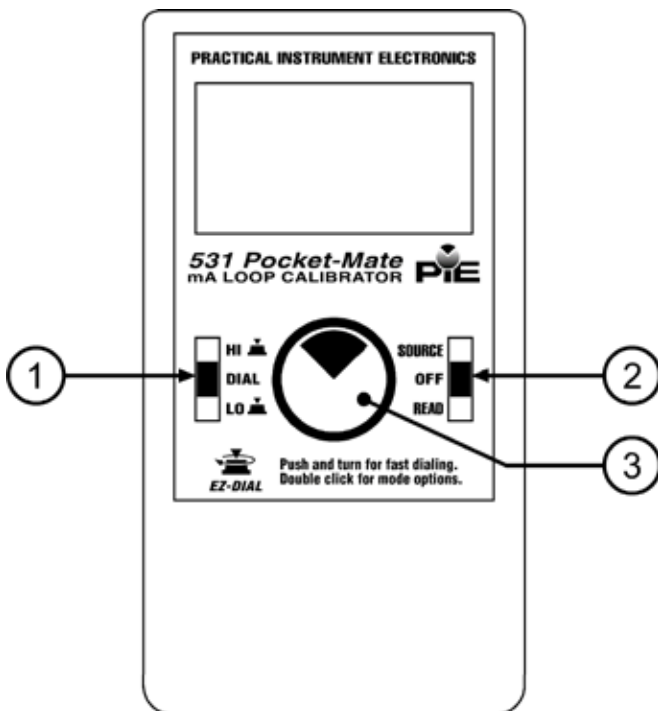

EZ-Dial™ Knob

Adjust the output up and down with the EZ-Dial knob. The increment is 0.01 mA (or 0.1 % if display units are % of 4-20 mA.) Press while turning to adjust 10X faster – 0.10 mA (or 1.00 %.)

Quick Reference Bar Graph

The Quick Reference Bar Graph indicates the input and output level to the Model 531 in % of 4-20 mA with 1.0% resolution. If the input or output signal is outside the normal operating range of the Model 531 the Quick Reference Bar Graph in source mode will flash, in Read mode display over range when above 24.5mA.

Error Conditions

Bar Graph will flash when any error conditions exist.

HART® Protocol

Remove the back of the case and remove the jumper that is located in position J6 on the PC board. By doing so it places a 250Ω resistor in series with the output of the model 531. This internal resistor eliminates the need to add an external load resistor when communicating with a HART® transmitter. This reduces the typical drive capability to 950Ω.



Model 531 Operating Instructions

EZ-Check™ Switch

The EZ-Check™ switch has three positions -- high, dial, and low. Its position is shown at the left edge of the display with "HI" and "LO" indicators. Neither indicator indicates the middle position. Use of the EZ-Check switch depends on mode.

Source Modes:

Slide the EZ-Check switch to the HI and LO positions to recall the preset settings (Hi=20.00mA & Lo=4.00mA).

Hint: For faster calibrations, the position of the switch can be felt. This feature allows continuous monitoring of the device being calibrated without looking back at the Model 531 display. This is also useful in poor lighting or under difficult operating conditions.

Read Modes:

In read mode, the Model 531 calibrator records the maximum and minimum readings observed in each mode. Slide the EZ-Check switch to the Dial position to read the loop. Then Slide the EZ-Check switch to the HI and LO positions to display the max and min readings. Press **EZ-Dial knob** to clear the readings. The display will flash "CLEARED" to confirm.

Source Mode

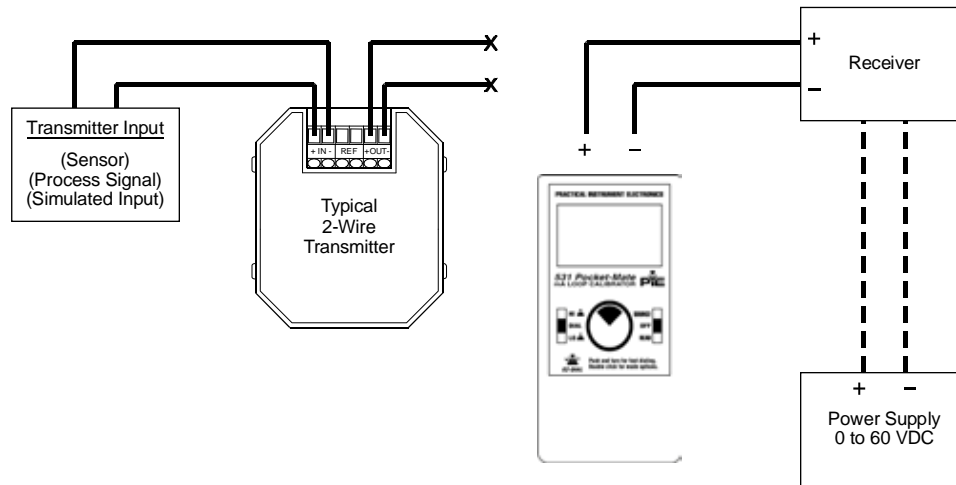

Source mode uses internal power to supply current from 0.00-24.00 mA into as much as 1200Ω until the end of battery life. The calibrator Graph will flash if connected improperly. The three-position EZ-Check switch provides instant preset 4mA at zero, 12mA at mid range and 20mA at full scale outputs. The output is adjusted in 0.01 or 0.10 mA increments (0.1 or 1.0) % display units with the EZ-Dial knob.

2-Wire Transmitter Simulation Mode

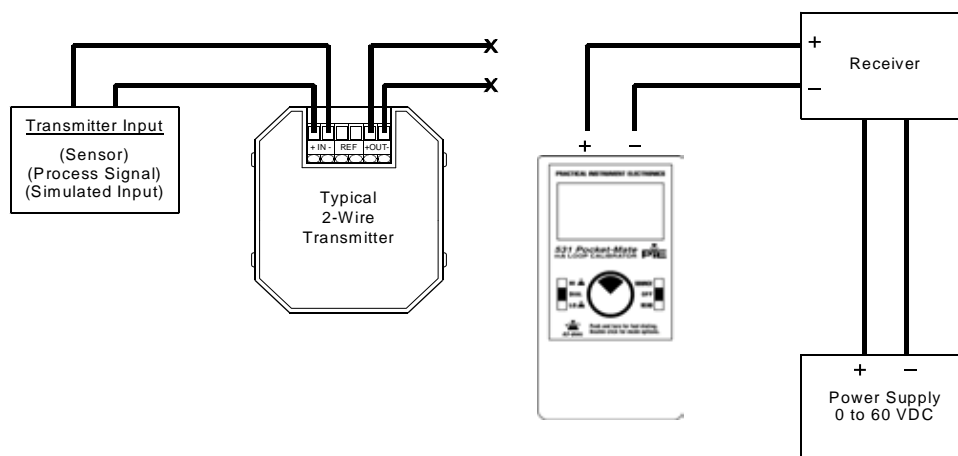

The Model 531 can simulate a 2-wire transmitter in the 4-20 mA or % process loop. In source mode press the EZ-Dial™ Knob twice to get into the feature options. Then press the EZ-Dial™ Knob to select mA 2 – wire. The EZ-Check switch and EZ-Dial knob allow rapid and fine control of loop current.

Power and Measure Transmitter Mode

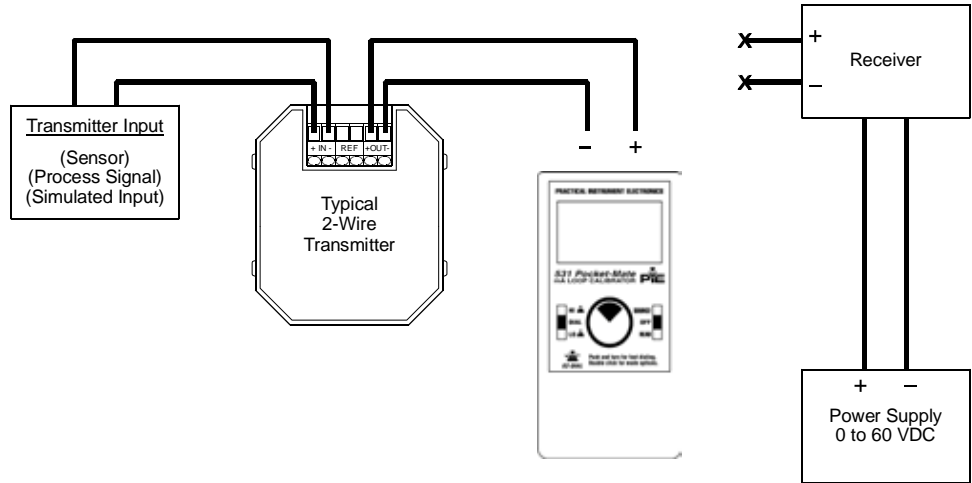

The Model 531 supplies 15Volts or 24 Volts to the transmitter and displays the output in mA or % on the Model 531 display. In read mode press the EZ-Dial™ Knob twice to get into the feature options. Then press the EZ-Dial™ Knob to select mA PWR - M. Then turn EZ-Dial™ Knob to select power range (15V or 24V). The EZ-Check switch and EZ-Dial knob allow rapid and fine control of loop current.

Read Mode

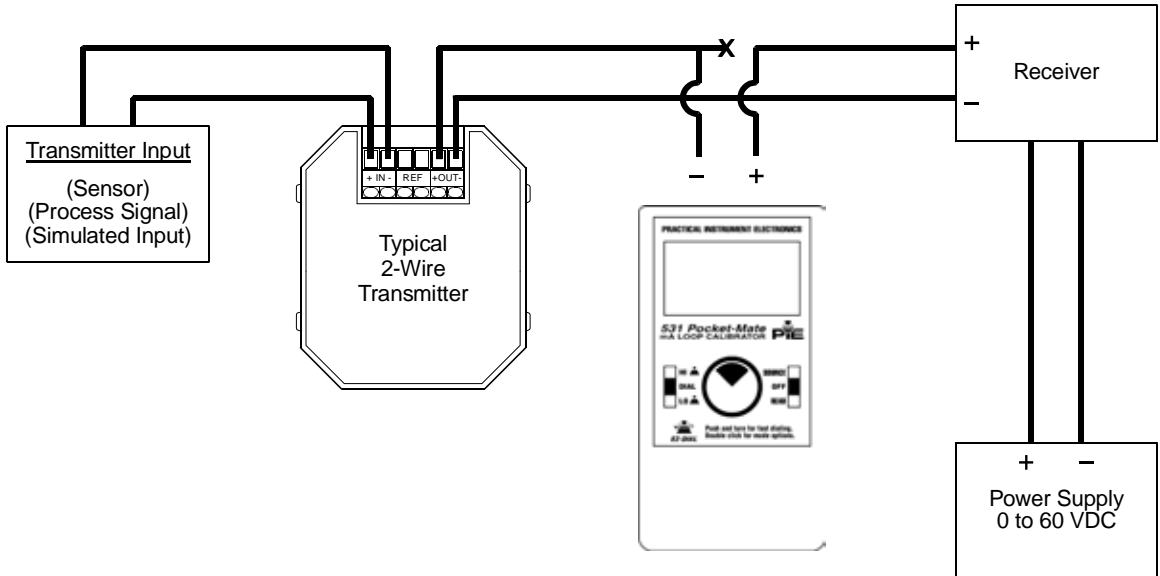

The Model 531 can read loop currents from 0-24 mA. The Model 531 limits current in read mode to 25mA to protect the devices in the loop from over voltage or over current conditions.



Model 531 Operating Instructions

Specifications

General Specifications:

(Unless otherwise indicated all specifications are rated from a nominal 23 °C, 70 % RH for 1 year from calibration)

Operating Temperature Range	-20 to 60 °C (-5 to 140 °F)
Storage Temperature Range	-30 to 60 °C (-22 to 140 °F)
Relative Humidity Range	10 % ≤RH ≤90 % (0 to 35 °C), Non-condensing 10 % ≤RH ≤ 70 % (35 to 60 °C), Non-condensing
Battery	2 AA Alkaline
Miscellaneous	Low battery indication with nominal 1 hour of operation left Over-voltage protection to 120 Vrms (rated for 30 seconds) or 240 Vrms (rated for 15 seconds) Bar graph display with 1% resolution of 4-20 mA signal scale High contrast graphic liquid crystal display with 0.45" (11.4 mm) high digits

Common Specifications for all current modes

Ranges	0.00 to 24.00 mA, 25.0 to 125.0% of 4-20 mA
Accuracy	≤ ± (0.05 % of Reading + 0.01 mA)
Temperature effect	≤ ± 50 ppm/°C of Range
Resolution(s)	0.01 mA and 0.1 %

Source/Power and Measure 2-Wire Transmitter Specifications:

Loop compliance voltage	≥ 15 Volts or ≥ 24 Volts
Loop drive capability	1200 Ω at 20 mA for entire battery life @ 24 Volts 600 Ω at 20 mA for entire battery life @ 15 Volts

Read mA Specifications:

Voltage burden	≤ 1V at 20 mA
Overload/Current limit protection	nominal ≤24 mA
Battery life	Typical ≥ 40 Hours

2-Wire Transmitter Simulation Specifications:

Voltage burden	≤ 2V at 20 mA
Overload/Current limit protection	nominal ≤ 24 mA
Loop voltage limits	2-42 VDC
Miscellaneous	Open loop or out of compliance conditions are indicated by appropriate error display Battery life ≥ 40 hour typical

Warranty

Our equipment is guaranteed against defective material and workmanship (excluding batteries) for a period of three years from the date of shipment. Claims under guarantee can be made by returning the equipment prepaid to our factory. The equipment will be repaired, replaced or adjusted at our option. The liability of Practical Instrument Electronics (PIE) is restricted to that given under our guarantee. No responsibility is accepted for damage, loss or other expense incurred through sale or use of our equipment. Under no condition shall Practical Instrument Electronics, Inc. be liable for any special, incidental or consequential damage.